

180604 /.- 605



MEMBER'S s.p.a.

COSTRUZIONI ELETTROMECCANICHE

Via Ghiacciaia, 1 - 37045 LEGNAGO (Verona) ITALY

Tel. 0039-0442-606200 - Telefax 0039-0442-28855 - E-mail: members@members.it

TELERUTTORE GENERALE DI CORRENTE ELECTRICAL BATTERY ISOLATOR SWITCH

Versione Version	Tensione nom. 12V Nominal voltage 12V	Tensione nom. 24V Nominal voltage 24V
Stacco al Negativo Negative disconnection	08094600	08094400
Stacco al Positivo Positive disconnection	08094700	08094500
Stacco al negativo o positivo Negative and positive disconnection	08094900	08094800

DIMENSIONI/SIZE:

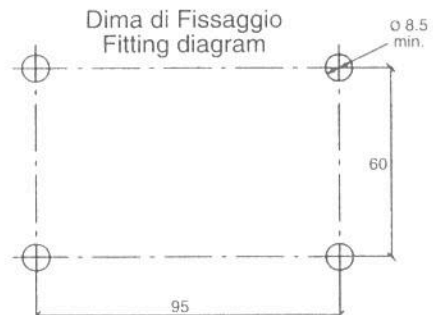
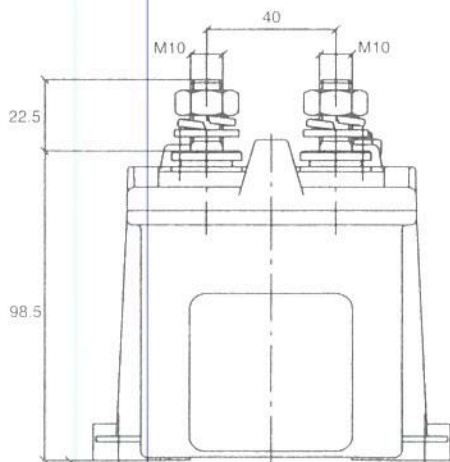
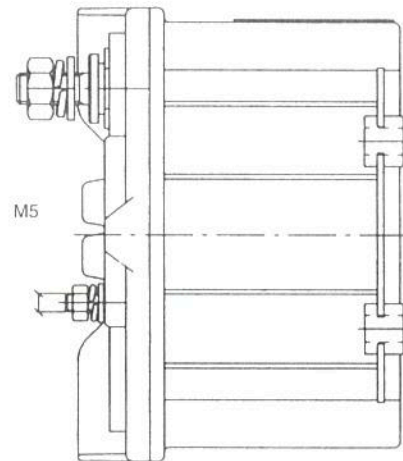
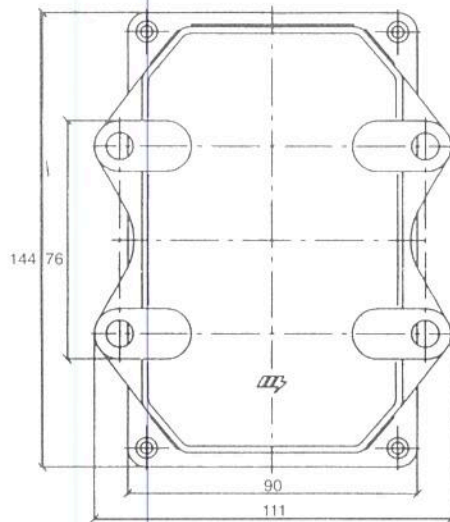

Cod. 80173401

SCHEMA ELETTRICO/ELECTRICAL DIAGRAM:

- Versione stacco a negativo
- Tensione nominale 12V e 24V

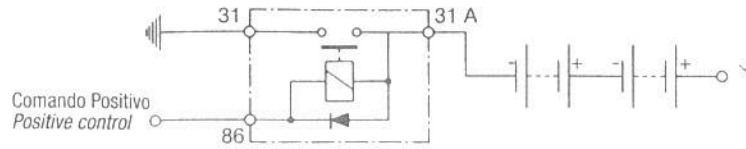

- Version with negative disconnection
- Nominal voltage 12V and 24V positive power supply coil

- Versione stacco a positivo
- Tensione nominale 12V e 24V

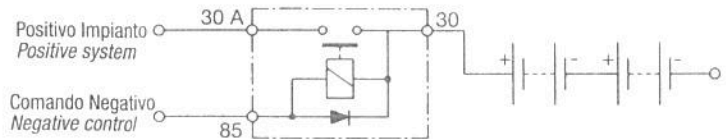

- Version with positive disconnection
- Nominal voltage 12V and 24V positive loads power supply coil negative

- Versione stacco al negativo o positivo, con alimentazione bobina separata
- Tensione nominale 12V e 24V

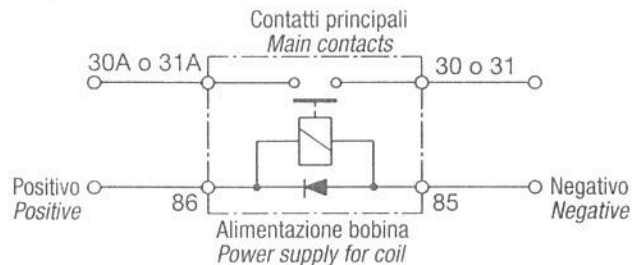

- Version with negative or positive disconnection, with separate power supply to the coil
- Nominal voltage 12V and 24V

DATI CARATTERISTICI / TECHNICAL SPECIFICATIONS:

Caratteristiche/Characteristics	12V Versione Version	24V Versione Version	U.M.	Condizioni Conditions
Tensione Nominale (Vn) / Rated operating voltage (Vn)	12	24	V	
Corrente max contatti continua / Max continuous current on main contacts	250		A	23°C
Corrente max contatti breve durata / Max short time current on main contacts	2500		A	23°C
Assorbimento max bobina / Max retaining coil	4,4	3,4	A	23°C Vn
Assorbimento nominale bobina / Nominal retaining coil	0,4	0,3	A	23°C Vn
Temperatura limite di esercizio / Operating temperature range	-30÷+60		°C	
Grado di protezione / IP protection grade	IP65			Secondo CEI/IEC 529:1989 According to CEI/IEC 529:1989
Coppia max chiusura dadi M10 / Tightening torque M 10 nuts	20		Nm	
Coppia max chiusura dadi M5 / Tightening torque M 5 nuts	1,6		Nm	

ISTRUZIONE PER IL MONTAGGIO / FITTING INSTRUCTIONS:

- Il teleruttore deve essere posizionato il più vicino possibile alle batterie.
- Può essere montato su telaio secondo la dima di fissaggio riportata nel disegno degli ingombri, utilizzando viti TCEI (Testa Cilindrica con Esagono Incassato) M8 UNI 5931:1984 e rosette piane 8,4x1,7 UNI 6592:1969 sottotesta.
- L'inversione dell'alimentazione della bobina comporta l'avaria del diodo interno.

- The battery isolator switch must be placed as close as possible to the batteries.
- It can be fixed to the frame according to the fitting diagram shown in the drawing, using M 8 TCEI (cylindrical head – encased hexagon) screws UNI 5931: 1984, and plain washers 8,4x1,7 UNI 6592:1969.
- The inversion of the power supply to the coil causes serious damage to the internal diode